

Populus to Ben Lomond

345kV transmission line project

As part of a \$4.1 billion investment in new transmission facilities announced in 2007, Rocky Mountain Power plans to construct a new double-circuit 345 kilovolt (kV) transmission line from the Populus substation to be built near Downey, Idaho to the existing Ben Lomond substation in Box Elder County, Utah.

Project purpose and need

Rocky Mountain Power is committed to providing safe, reliable electrical service to its customers in Utah, Idaho and Wyoming in the most efficient and cost-effective manner. Due to population growth and the increasing needs of existing customers, the company will need additional transmission capacity in the next 10 years to meet its obligations. The new transmission line will connect the southeast Idaho transmission system to the Wasatch Front to serve the growing electrical needs of customers. The new transmission line and substation will also provide improved operational flexibility in conjunction with future generation resources, including renewable resources such as wind.

Project description

The project will consist of the following new or expanded facilities:

- A new 345kV substation (Populus) located near Downey, Idaho along an existing high voltage transmission line corridor will be the northern terminating point of the new transmission line. Initially, a 345kV substation yard will be developed at Populus, but it also will be configured to facilitate additional transmission lines in the future.
- A new 345kV double-circuit transmission line will be constructed in a new right of way corridor from the Populus substation to the existing Ben Lomond substation in Box Elder County, Utah, a distance of approximately 90 miles.
- The Ben Lomond Substation will be expanded on company-owned property to accommodate the new line.
- Construction of new access roads and improvement to existing access roads will be needed along the 345kV transmission line between Ben Lomond and Populus to provide for construction and maintenance activities.
- Temporary work areas will be developed for construction activities and site preparation work.

(continued)



This map shows the Populus to Ben Lomond transmission corridor project area. Rocky Mountain Power is planning to add a new transmission line to meet growing demand and better serve customers.

Populus to Ben Lomond

345kV transmission line project

Route selection process

During the past year Rocky Mountain Power has been conducting an in-depth substation and transmission line siting study. Numerous route and substation alternatives were considered for the location of the proposed facilities. Criteria used to identify the preferred route and substation site included: community, social, environmental, technical, and land-use factors, and the economic aspects of these alternatives. The analysis has been completed and the preferred line route and Populus substation site have been selected.

Structure type

- Single-pole steel structures, approximately 125-150 feet tall, will be used for the transmission line.
- Structures will be placed 600-900 feet apart, or about 6-8 structures per mile.

Project timeline

Rocky Mountain Power is currently in the process of meeting with the agencies and others impacted to gather their input regarding the project. Public open house meetings, scheduled in January 2008, will provide local residents general project information as well as information specific to the facilities proposed in the immediate area. Required permits will then be prepared and submitted for approval. Once the permitting process is completed and the required permits have been approved, construction of the project will begin. The schedule for the project is:

- **Stakeholder/Agency briefings:** August – November 2007
- **Public Informational Open House Meetings:** January 2008
- **Project permitting:** February 2008 – September 2008
- **Project construction:** June 2008 – June 2010
- **In-service date:** June 2010

Contact information

For more information visit Rocky Mountain Power's Web site at: www.rockymountainpower.net/transmission.

To submit a question or comment, contact us by e-mail at ConstructionProjects@pacificorp.com or call 801-220-4221.

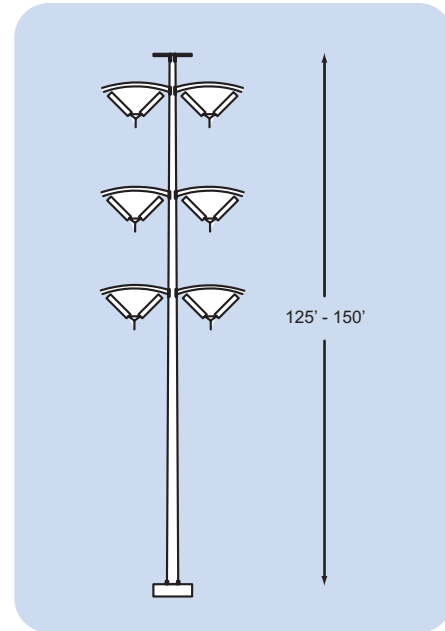

Typical 345kV structure to be used in the new transmission line project.